

Mayor of London

OUR PLAYSCAPE IN NEW CROSSES



REIMAGINE

&

REACTIVATION

Mayor's Foreword

There are lots of kids in london. There are more kids than adults i think! but we are smaller than the adults so when the adults walk around they can not see us because they don't look down. they are always being very serious all the time and should be having lots more fun. I want you to take a walk in my shoes and play everywhere because you can, but my shoes are small.

The playground is everywhere and I want to play everywhere. It is really important that the adults have more fun because that will mean we can have more fun and fun makes people happy. I want to play everywhere but I am not allowed. I have been talking to my friends at school and they also want to play everywhere, this is a key piece of evidence that informs Supplementary Planning Guidance on play and recreation.

I am establishing a crack team/advisory board of creative child consultants to supervise and aid the re-imagining of urban development and planning. Their job? To bridge the gap between adults and children, reality and imagination. what kind of experience would a child want in an adult space? A child's materials in construction, alternatives and compromises from the natural concrete and steel beams, bring into urban space new energy and perspective. Realising a child's idea of an adult space allows us to question our pre-conceived ideas of scale in architecture, and allows us to consider improvements that children would imagine in our urban landscape.

Me and my friends have done some drawings and they are really good so we are gonna make them in real things because they are fun.

Signed -
Sadiq Khan, Mayor of London



Sadiq Khan 

What's the purpose of this?

Its an invitation to play. For us as children to play with the city, a space according to convention than is against play and strictly confines play to the playground. As well as you adults. To allow you to see, to remember and to reconnect with play as a key element in a child's growth and well being.

Because why can't we play everywhere? Answer us that?

Rather, we've come up with some demands of our own on the city, they are as followed:

WE DEMAND PLAY

WHERE - EVERYWHERE - IN EVERY CITY, IN EVERY TOWN, IN EVERY STREET, IN EVERY HOUSE - PLAY.

WE DEMAND PLAY IN THE CITY WITH NO BLOCKS BETWEEN THE PLAYGROUND AND ADULT PLACES.

WE DEMAND PLAY ON EVERY SURFACE, AREA, BUILDING, STRUCTURE SO WE CAN BE ADVENTUROUS, CUSRIOUS AND PLAYFULL.

WE DEMAND PLAY USING MATERIALS, STRUCTURE, COLOUR AND FUNCTION TO BRING PARENTS, GRANDPARENTS AND US TOGETHER SO WE CAN UNDERSTAND EACHOTHER AND BECOME CLOSER.

WE DEMAND PLAY IN THE CITY SO OLDER PEOPLE CAN UNDERSTAND AND DEVELOP A NEW FRIENDSHIP WITH PLAYING TO HELP THEM LOOK AT THE CITY DIFFERENTLY.

WE DEMAND PLAY IN THE CITY TO BE FUN AND IT DOESN'T NEED TO BE JUSTIFIED OR EXPLAINED.

WE DEMAND PLAY TO BE PUT IN PLACE WHERE THE CITY IS BROKEN, THIS WILL MAKE THE AREA BETTER FOR CHILDREN AND ADULTS.

WE DEMAND PLAY TO GIVE US OUR OWN PLAYSCAPE TO LIVE IN.



WE DEMAND PLAY - A MERGING OF PLAY.

We've demanded this from our research. We found out that the city doesn't like us and we really don't like that much of the city, its quit big and scary. But if it was playful, fun, safe and on our scale then things could be a lot better.

Because we want to play everywhere, we can see the fun to be had, we can imagining it, dream it. Because we can, its natural to us to envision play, activate play and building on play within our environment.

why can't you see the city through our glasses, or can you?

These are special glasses that allow you to see how we see, to see play.

See As
A Child See's,
Reconnect
with the
Passion and
Dreams of Play

Start remembering how
important play was to you.

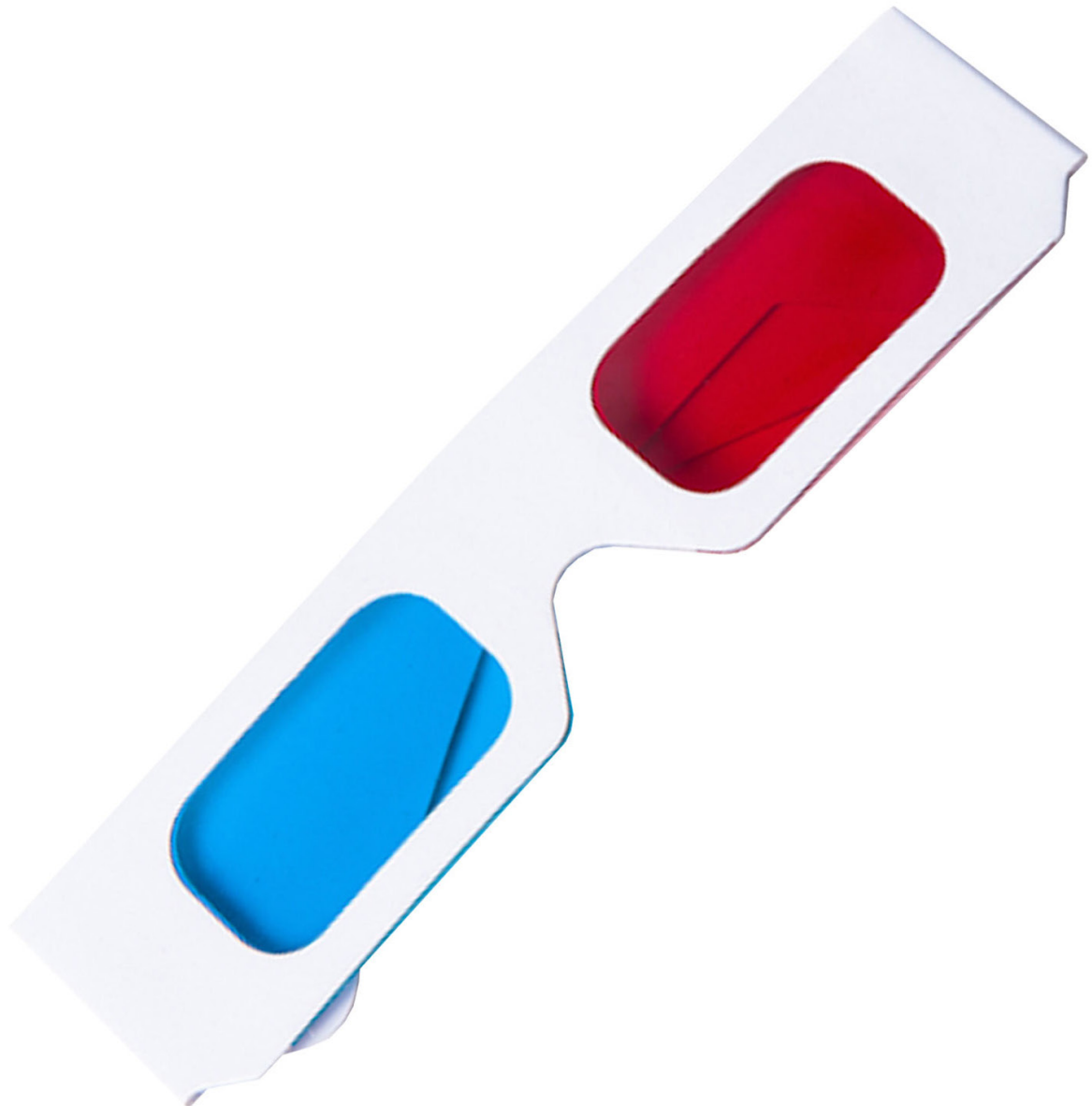



Our vision of the city.

This next bit is about recognising the importance of play as a part of the city. You may think there's other stuff to be doing, we know you are busy, but please see the potential for improving the life of citizens of all ages through our vision and exercises.

At the local level of 15 minute cities the Play Streets movement is beginning to influence planning and development, with communities reclaiming streets as spaces to socialise, gather and play.



An adult notices aspect of the city in the established manner. For example, a warning sign alerts the adult of danger, the design of the sign intends to be recognisable, authoritative and understandable.

A child notices different aspect, because of differences in scale; which means a sign could be too big or too high up; but also, signs are meant for adults and children are told not to worry about them. They generally are informed by recognisable forms in different objects, and they can use this in play with their imagination. This differs from adults by its neglect of the order and function of urban geography, using it in unintended ways.

When a child sees a "no ball games" sign, they enter into this adult way of seeing the city. They become informed by the sign's intentions, which are directly for them. The child is affected by the city in equal manner as the adult, but it is also in detriment to their wants and intentions. The adult will happily "play ball games" elsewhere but child will feel interrupted and discouraged.

These signs flip this detrimental design negative. The sign becomes a prompt to play, the adult becomes the child, the urban geography welcomes the child, and everyone is in better perspective of each other.



He he
You can not
reach me



Our vision of the city .



follow the faces

how are you feeling today?





are you happy or sad or scared?



why dont you follow your emotions and see where it will lead you



Our vision of the city .

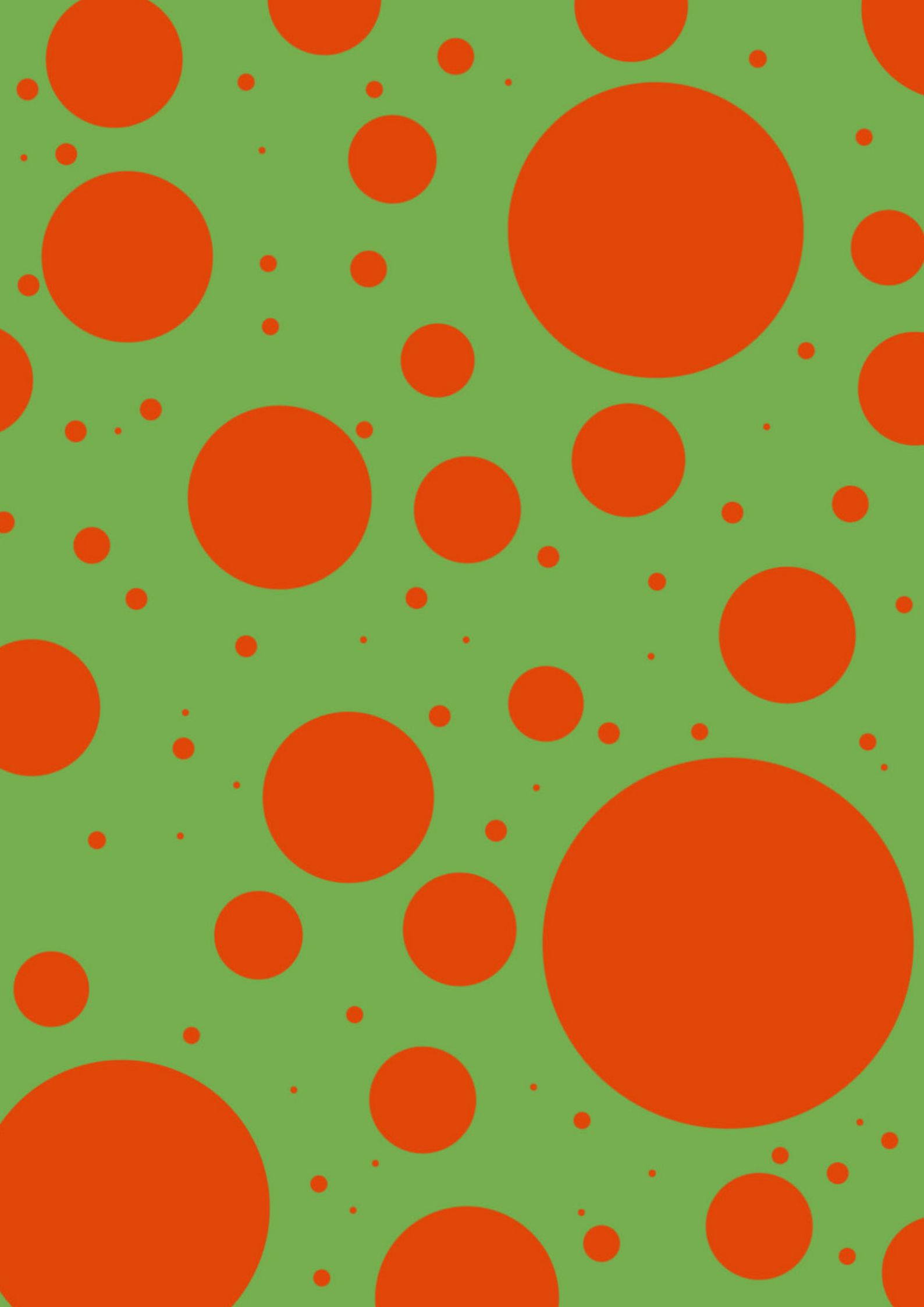

How To: City Fishing Rod

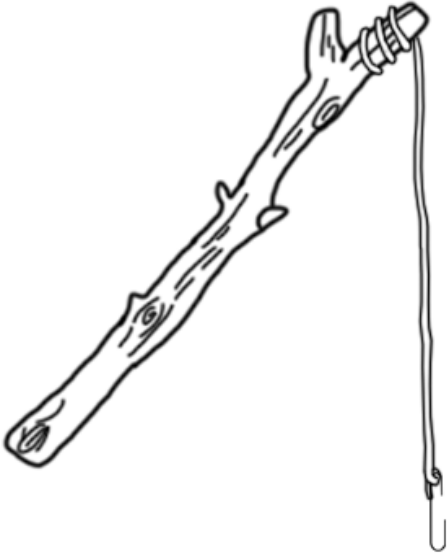
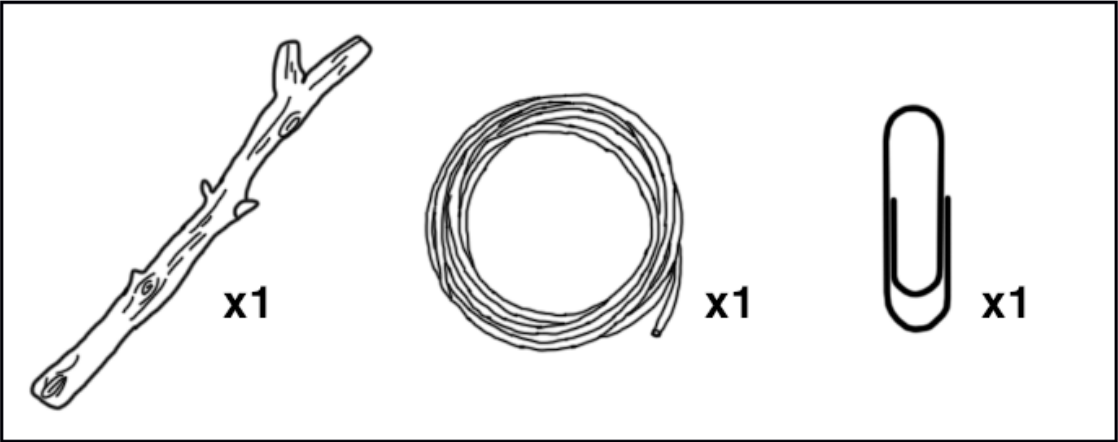

1. Tie string around end of stick.

2. Tie knot in end of string.

3. Hook paperclip into knot.

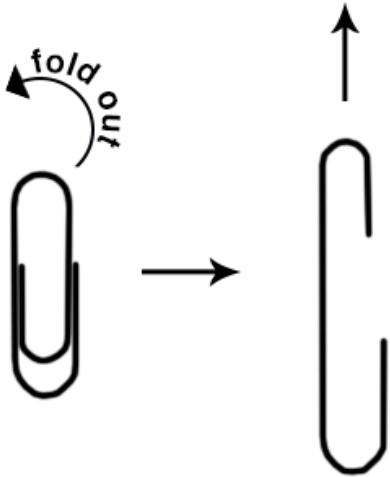

Our vision of the city .

A fishing trip in the city using a DIY fishing rod and your imagination



How To: Boating Holiday

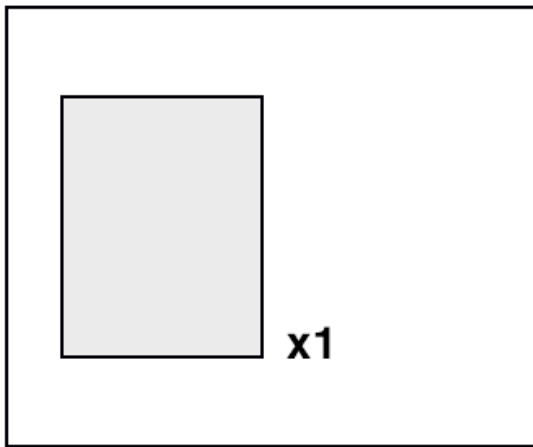

fold paper

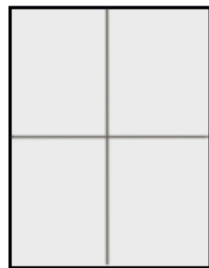

fold in corners

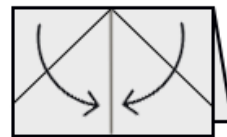

fold up edges

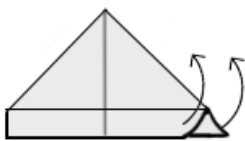

pull out sides

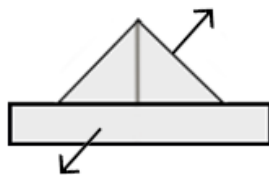

fold up front and back

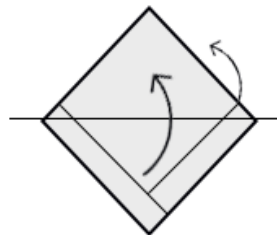

pull out sides

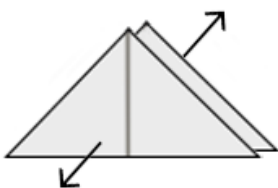

pull outwards

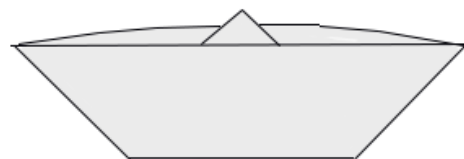
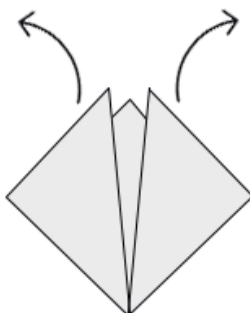

Our vision of the city .

A boating holiday In the city using DIY boats and your imagination, Fun for all generations.



Become the builder, construct your own city from what you find and rediscover the element of play that's been lost. these are examples of forts we've made...

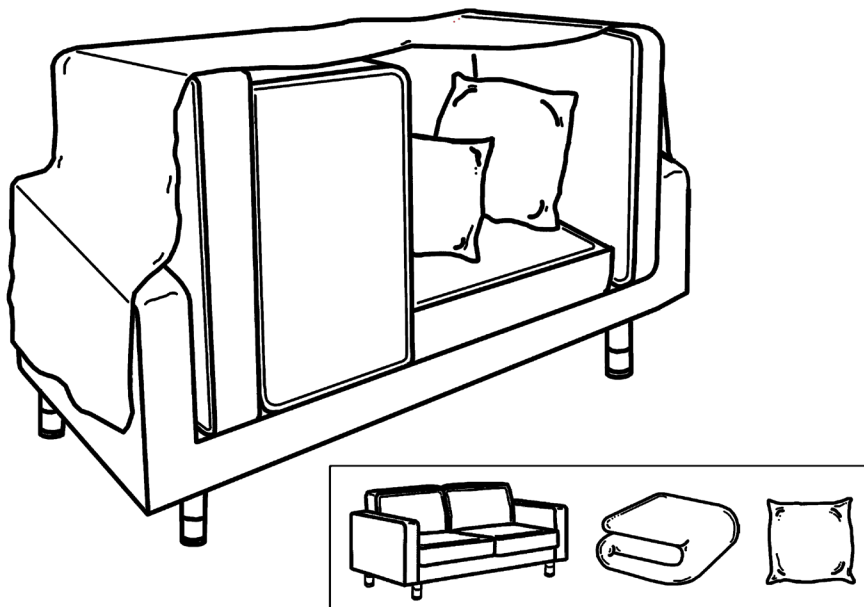
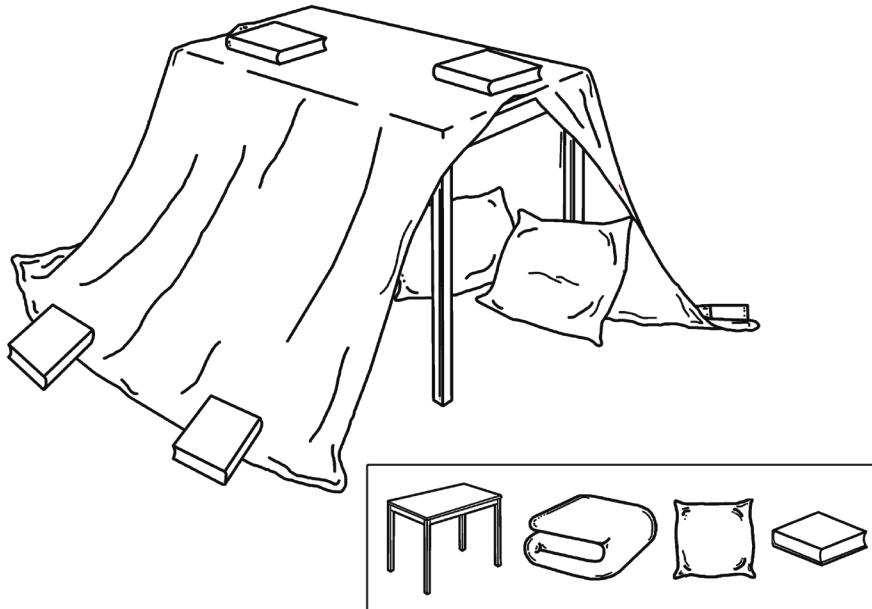
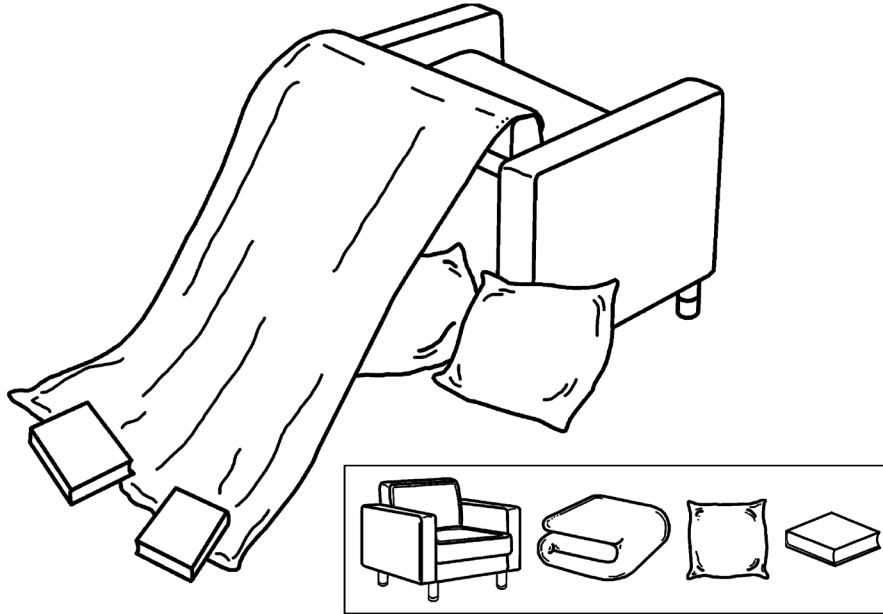

Our vision of the city .

These are imaginative play-object 'add-ons' allowing child inclusivity through play. These building upon the existing environment within the 15-minute city. Expanding play, through building upon play beyond the playground. A merging of play in city.

What if you give it a try?





Our vision of the city .

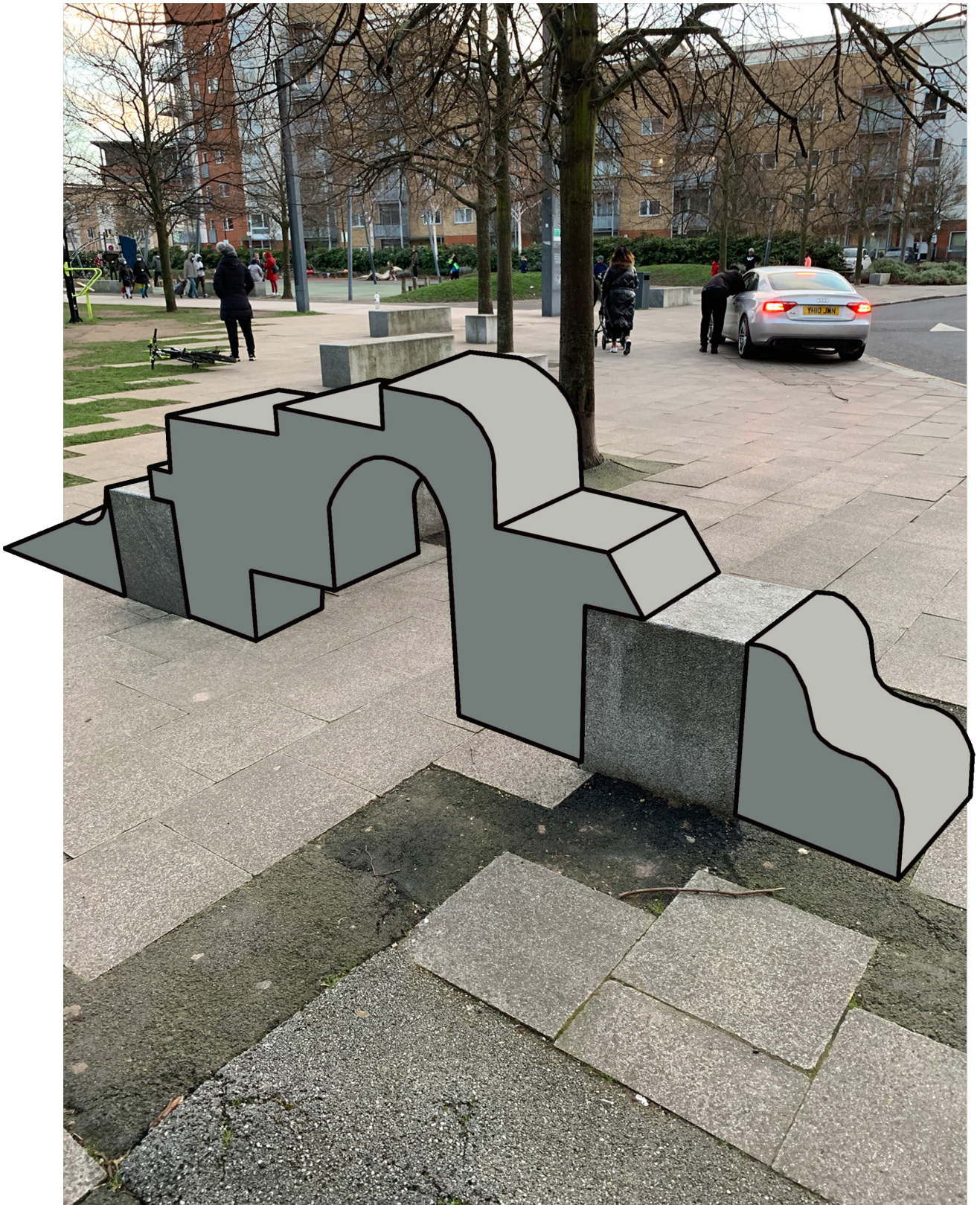

Tunnel In Traffic.



The all new regression shoes.

Ow, feel the ground and the surfaces below. Let the colossus tower.
crawl through the world on your knees.



perspective pince-nez

Disown your spatial awareness.
View the world from the perspective you once found natural.



Our vision of the city .

activities in the city

Quickly! Quickly! The floors turning to lava, climb, run, jump to safety in the city.

Embrace the rough and tumble, climb on the benches, run, skip, and jump across the city.

High in the sky, navigate your way across the city using everything in your path, let the pavement become stepping stones across the fierce waters.

Can you hear the chimes? navigate your way with the sounds of the city streets as you bang and clatter your way through.

Shrink the city! weave new paths within your journey, discover what isn't seen and make it new.

Become the builder, recreate the city for all thinking of play as the key ingredient for these new objects of play.

**BEWARE! Watch out for those paving stone cracks, you've heard the tale haven't you? If you step on a crack you break your back, if you step on a line you'll break your spine.
Please tread carefully!**



City Delvelopment From Charlie Aged 6

Children City Planners.



Elliott aged 6.



Harriet aged 4.



Erik aged 5.



Natasha aged 6.

REIMAGINE

&

REACTIVATION

